



YSR315S303



1. SCOPE

This specification shall cover the characteristics of 1-port SAW resonator with YSR315S303 used for remote-control security.

2. ELECTRICAL SPECIFICATION

2.1 Maximum Rating

DC Voltage VDC	10V
AC Voltage Vpp	10V 50Hz/ 60Hz
Operation temperature	-40°C to +85°C
Storage temperature	-45°C to +85°C
Max Input Power	10dBm

2.2 Electronic Characteristics

Item	Unites	Minimum	Typical	Maximum	
Center Frequency	MHz	314.925	315.000	315.075	
Insertion Loss	dB		1.4	1.9	
Quality Factor	Unload Q	8000	12800		
	50Ω Loaded Q	1000	2000		
Temperature	Turnover Temperature	°C	10	25	40
Stability	Freq.temp.Coefficient	ppm/°C ²		0.032	
Frequency Aging		ppm/yr		< ± 10	
DC. Insulation Resistance	MΩ	1.0			
Transducer Static Capacitance C0	pF		2.13		

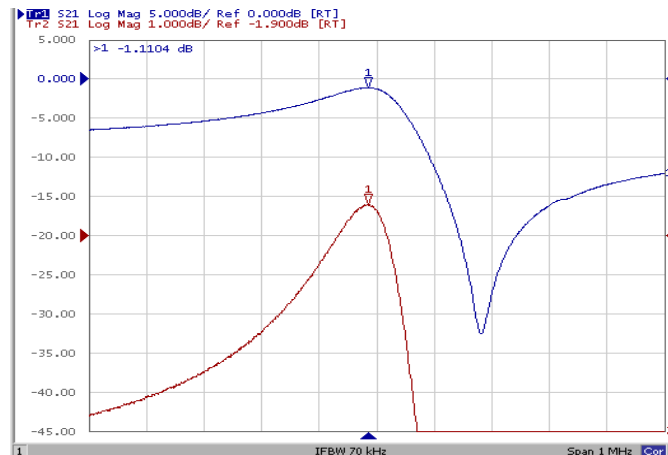



YSR315S303



2.3 Equivalent LC Model

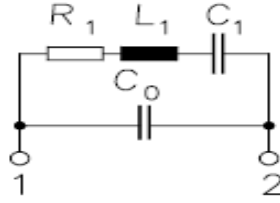

3. TEST CIRCUIT

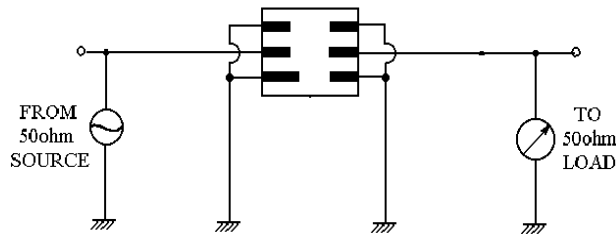

4. DIMENSION

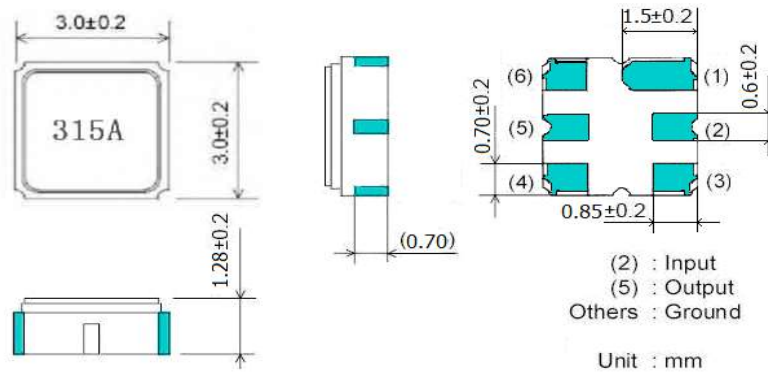



YSR315S303



5. ENVIRONMENT CHARACTERISTIC

5-1 High temperature exposure

Subject the device to +85°C for 16 hours. Then release the filter into the room conditions for 24 hours prior to the measurement. It shall fulfill the specifications in 2-2.

5-2 Low temperature exposure

Subject the device to -40°C for 16 hours. Then release the device into the room conditions for 24 hours prior to the measurement. It shall meet the specifications in 2-2.

5-3 Temperature cycling

Subject the device to a low temperature of -40°C for 30 minutes. Following by a high temperature of +85°C for 30 Minutes. Then release the device into the room conditions for 24 hours prior to the measurement. It shall meet the specifications in 2-2.

5-4 Resistance to solder heat

Dip the device terminals no closer than 1.5mm into the solder bath at 260°C ±10°C for 10 ±1 sec. Then release the device into the room conditions for 4 hours. The device shall meet the specifications in 2-2.

5-5 Solderability

Subject the device terminals into the solder bath at 245°C ±5°C for 5s. More than 95% area of the terminals must be covered with new solder. It shall meet the specifications in 2-2.

5-6 Mechanical shock

Drop the device randomly onto the concrete floor from the height of 1m 3 times. the device shall fulfill the specifications in 2-2.

5-7 Vibration

Subject the device to the vibration for 1 hour each in x, y and z axes with the the amplitude of 1.5 mm at 10 to 55Hz. The device shall fulfill the specifications in 2-2.

6. REMARK

6.1 Static voltage

Static voltage between signal load & ground may cause deterioration & destruction of the component. Please avoid static voltage.

6.2 Ultrasonic cleaning

Ultrasonic vibration may cause deterioration & destruction of the component. Please avoid ultrasonic cleaning

6.3 Soldering

Only leads of component may be soldered. Please avoid soldering another part of component.



YSR315S303



7. PACKING

7.1 Dimensions

- (1) Carrier Tape: Figure 1
- (2) Reel: Figure 2
- (3) The product shall be packed properly not to be damaged during transportation and storage.

7.2 Reeling Quantity

- 1000 pcs/reel 7"
- 3000 pcs/reel 13"

7.3 Taping Structure

- (1) The tape shall be wound around the reel in the direction shown below.

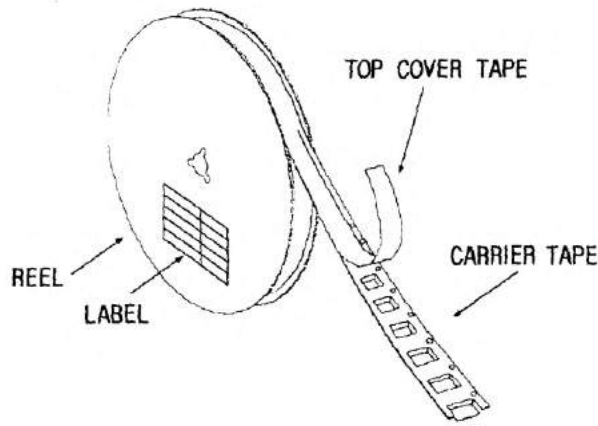

(2) Label

Device Name	
User Product Name	
Quantity	
Lot No.	

(3) Leader Part and vacant position specifications.

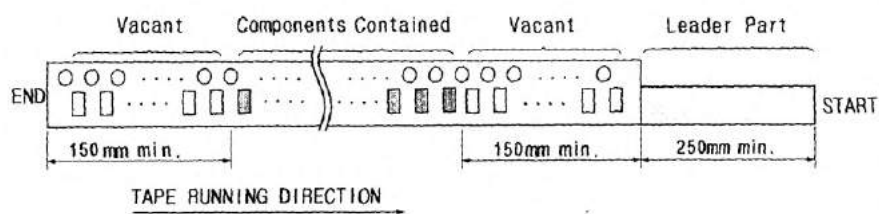



YSR315S303



8. TAPE SPECIFICATIONS

8.1 Tensile Strength of Carrier Tape: 4.4N/mm width

8.2 Top Cover Tape Adhesion (see the below figure)

(1) pull off angle: 0~15°

(2) speed: 300mm/min.

(3) force: 20~70g

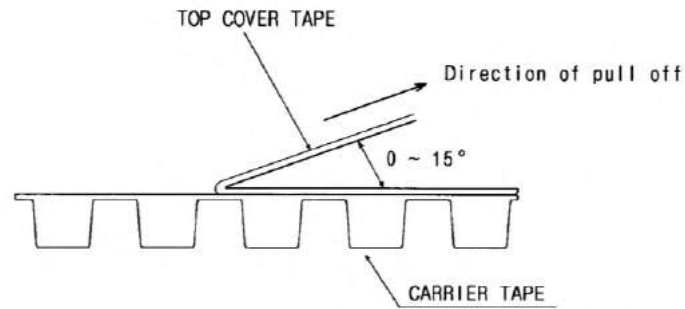

[Figure 1] Carrier Tape Dimensions

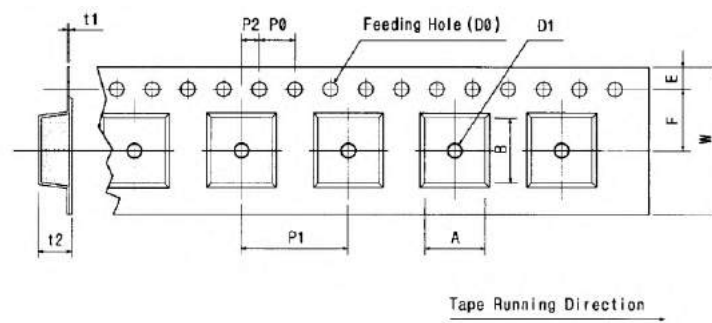

[Unit: mm]

W	F	E	P0	P1	P2	D0	D1	t1	t2	A	B
12.0	5.5	1.75	4.0	4.0	2.0	Ø1.5	Ø1.0	0.3	1.25	3.3 ± 0.1	3.3 ± 0.1



YSR315S303



[Figure 2] Reel Dimensions

